

Katrin Distributeur de papier toilette plié

92582

- Pour papier toilette plié.
- Distribution feuille à feuille hygiénique.



ISO 9001 ISO 14001

Produit



x 158 mm
y 307 mm
z 133 mm



Blanc



0,515 kg

Emballage pour le transport

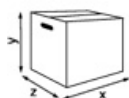

x 180 mm
y 320 mm
z 145 mm



1



0,729 kg



6414300092582

Information concernant la palette

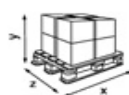

x 800 mm
y 2360 mm
z 1200 mm



216



182,614 kg



6414300092599

Dimensions

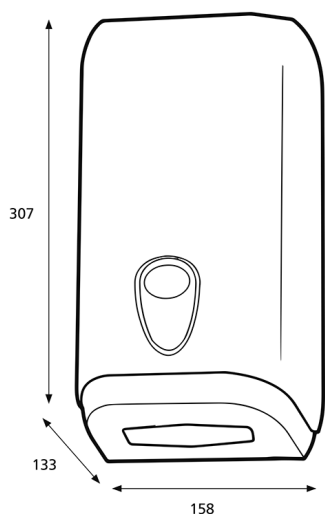

Instructions de montage

