

# Katrin Toilettenpapierspender 2-Rollen

104452

- Praktischer Spender für konventionelle Toilettenpapierrollen.
- Für 2 Toilettenpapierrollen gleichzeitig (mit einem Durchmesser von max. 115 mm).
- Aus ABS-Kunststoff, robust und zuverlässig.
- Sichtfenster zeigt an, wann Papier nachgefüllt werden muss.
- Geeignet für Eckanbringung rechts und links (Rollenhalter austauschbar).
- Einfaches Befüllen, Anbringen und Pflegen.
- Abschließbar.



ISO 9001 ISO 14001

## Produkt



x 145 mm  
y 300 mm  
z 145 mm



Schwarz



0,71 kg

## Transportverpackung

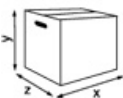

x 160 mm  
y 310 mm  
z 160 mm



1



0,9 kg



6414300104452

## Paletteninformation

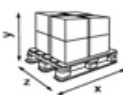

x 800 mm  
y 2550 mm  
z 1200 mm



255



254,65 kg



6414300104469

## Abmessungen

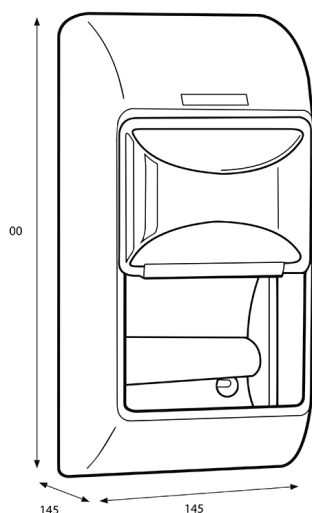

## Montageanleitung

