

Katrin Toilet 2-Dispensador de rollos para lavabos

92384

- Dispensador práctico para rollos de papel higiénico convencionales.
- Para 2□rollos de papel higiénico a la vez (con un diámetro máximo de 115□mm).
- De plástico ABS, resistente y fiable.
- Con ventanilla para ver cuándo se debe recargar el papel.
- Adecuado para colocarlo en las esquinas, tanto a la derecha como a la izquierda (portarrollos intercambiable).
- Instalación, recarga y limpieza sencillos.
- Con cerradura.



ISO 9001 ISO 14001

Producto



x 145 mm
y 300 mm
z 145 mm



Blanco



0,71 kg

Envase de transporte

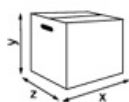

x 160 mm
y 310 mm
z 160 mm



1



0,9 kg



6414300092384

Información de palets

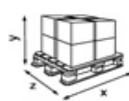

x 800 mm
y 2550 mm
z 1200 mm



255



254,65 kg



6414300092551

Medidas

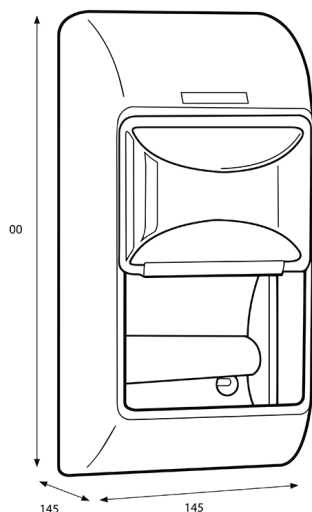

Instrucciones de montaje

